

**STRESS BREAKERS IN REMOVABLE  
PARTIAL DENTURES**

**DR VISHAL CHAUHAN  
ASSOCIATE PROFESSOR  
Department of Prosthodontia,  
Govt. Dental College And Hospital,  
Ahmedabad.**

## ❖ INTRODUCTION:

- In the chapter of designing of removable partial denture, the stresses acting upon the partial denture were discussed.
- But in unusual conditions certain stress breaking elements can be successfully incorporated into the prosthesis to reduce stresses on the prosthesis.
- All the horizontal and vertical forces applied to the abutment teeth and the prosthesis are distributed throughout the supporting portions of the dental arch.
- These broad distribution of the stresses are accomplished by either through the rigidity of the major connector or by including stress breakers.

- Many and varied stresses are imparted to the hard and soft tissue which bear distal extension partial denture. Some type of stress breaking action must be incorporated particularly when the patient has weakened abutment teeth.
- The ideal stress breaker does not exist and the dentist must provide the patient with maximum masticatory function and comfort and minimum damage to supporting structures
- Many attachments, primarily extracoronal and stud attachments provide for this stress directing effect.
- In distal extension situations, the use of a rigid connection between the denture base and supporting teeth must account for the base movements without causing either tooth or tissue damage.

## ❖ DEFINITION:

➤ *It is a mechanical device incorporated into the removable partial denture that allows some movement between the denture base or its supporting framework and the direct retainers, whether intra-coral or extracoral. (Mc Cracken)*

➤ *“A device or system that relieves specific dental structures of a part or all of the occlusal forces and redirects those forces to other bearing structures or regions.” (GPT 2005)*

➤ It is used in cases with distal extension base Kennedy class I and Class II cases where there is a need to evenly distribute the stresses to the abutment teeth and the residual ridge as well as absorbing the stresses which are applied to minimize the bone resorption.

## ❖ **STRESSES INDUCED TO THE PROSTHESIS:**

- For stresses to be broken or distributed it is of utmost importance to evaluate where exactly the forces are acted.
- The principal forces acting are as under:
  - (1) Stresses resulting from an inaccurate appliance.
  - (2) Stresses caused by an interferences to appliance insertion or removal.
  - (3) Stresses which may cause impingement of gingival tissues.
  - (4) Stresses which torque or twist the abutment of an extension-base prosthesis.
  - (5) Stresses which cause the proximal or lateral tilting of an abutment.
  - (6) stresses resulting in impingement of the gingival tissues.

### **(1)Stresses from applied inaccuracy:**

- Due to improper impression technique which may be due to improper impression recorded or due to errors in the laboratory duplication of the cast.
- Due to improper casting procedure. Improper investment techniques and materials may lead to defective castings that do not seat to the underlying tissues properly.
- Due to damage to the master cast before investing. Improper handling of the master cast before casting leads to surface abrasion in critical areas which may be detrimental to the success of the prosthesis.
- Excessive finishing and polishing of the completed prosthesis may lead to inaccurately fitting prosthesis which may lead to unfavorable forces to the underlying tissues.

## **(2) Stresses from the major connector:**

- It may be produced pinching of the underlying tissues
- It may be produced impingement during lateral shifting of the prosthesis.
- Stresses may be produced by flexing of the major connector, if the connector is too long or the abutment teeth supporting the prosthesis are weak.

### **(3) Stresses that twist or produce torque to the prosthesis:**

- They are more common amongst the distal extension tissue supported prosthesis rather than tooth-supported prosthesis.
- Another factor that aggravates lateral forces is the cusp inclines of the artificial teeth. Higher the cuspal inclines more are the lateral or torquing forces.
- Lateral forces can be avoided by splinting as many teeth as possible, provide rigid connection or by incorporating combination clasps.

- These factors can be relieved sometime by providing flexible connection between the denture base and the major connector by the means of either the flexible connections or the split major connector.

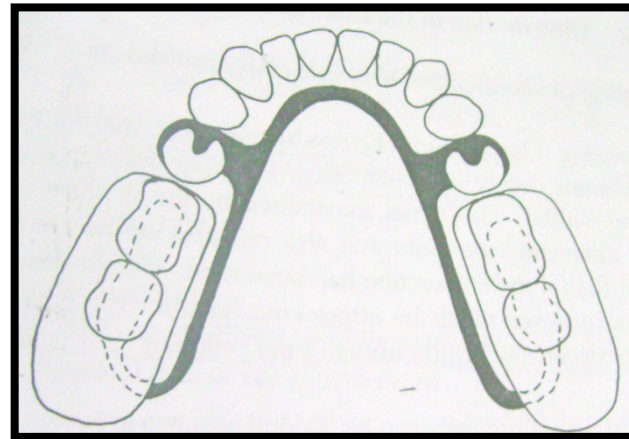
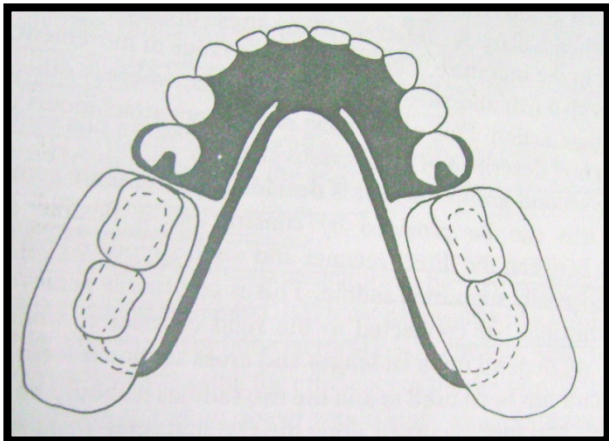

**Stress breakers in the form of split connectors**

## ❖ TYPES OF STRESS BREAKERS:

➤ Stress breakers can be divided into two main groups:

(1) First are those having a movable joint between the direct retainer and the denture base. the examples in this group are:

- Hinges
- Sleeves and cylinders
- Ball and socket devices

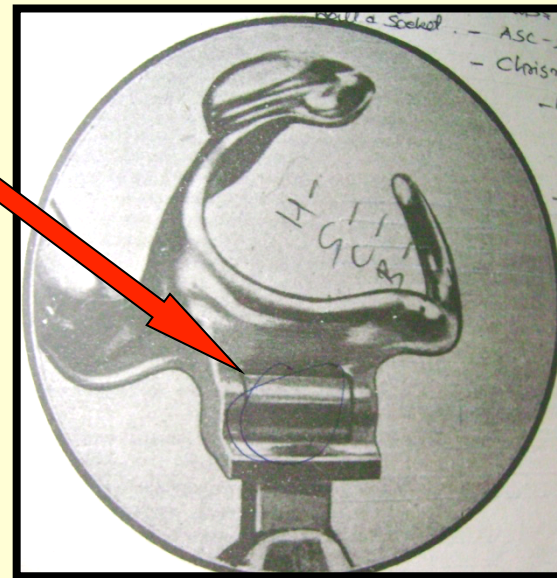

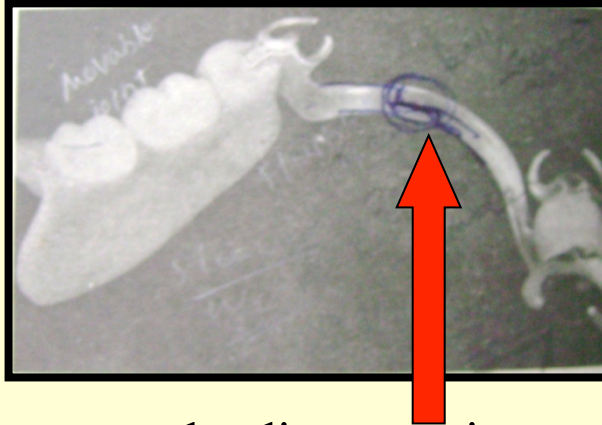

- They are placed between the direct retainer and the denture base and permit both horizontal and vertical movements and hinge action of the distal extension denture base.
- This help to prevent some direct tipping forces to the abutment teeth and the denture base during function.
- Most of these attachment are prefabricated but some of it are made in laboratory with dual casting technique.
- Because of fear of getting rapidly weared, these attachments are generally made up of harder alloys.

(2) The second group involves in which a *flexible connection* between the denture base and the major connector is given.

➤ These connection may be of different types such as:

- wrought wire connectors
- Divided major connectors
- Other flexible devices such as split major connector

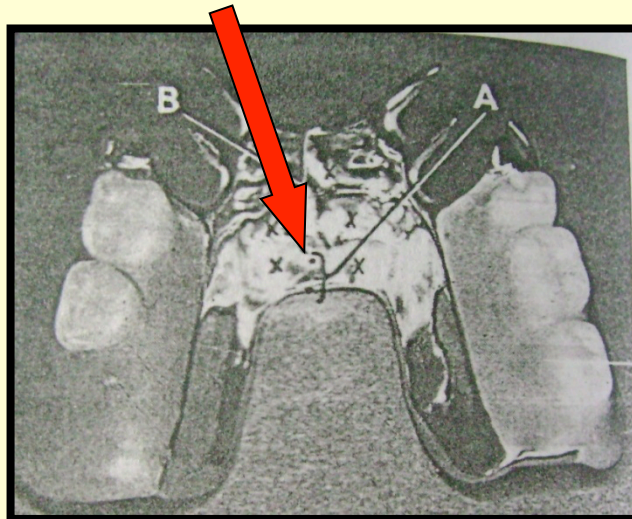

## ❖ **ADVANTAGES OF STRESS BREAKERS:**

- As the horizontal forces acting on the abutment teeth are minimized, the alveolar support of these teeth is preserved.
- There is a balance in force distribution between the denture base and the abutment teeth.
- Intermittent forces of the denture base on the mucosa massages the mucosa and thus provide physiologic stimulation, which further prevents bone resorption and eliminates need of relining.

## ❖ **DISADVANTAGES OF STRESS BREAKERS:**

- Usually more difficult to fabricated and more costly.
- The effectiveness of indirect retainers is reduced due to the movement of the denture base.
- Spaces between the flexible connectors are sometimes opened up which leads to food impaction ant irritation to the local tissues.
- The flexible joint may pinch the soft tissues in the floor of the mouth or the tip of the tongue leading to trauma.
- Repair and maintenance of the stress breaker is difficult, costly and time consuming without the desired results.

## ❖ ADVANTAGES OF RIGID DESIGN:

- Easier to construct and less costly.
- The need for relining the prosthesis is less.
- Indirect retainers and other rigid components may act to prevent rotational movements of the denture.
- As the number of flexible parts are reduced, the chances of the prosthesis being damaged are less.

## ❖ DISADVANTAGES OF RIGID DESIGN:

- Greater amount of torque will be applied to the abutment teeth.
- Rigid clasping may be harmful if not properly used.
- If relining is not done when needed, the abutment tooth may get loosened and suffer from periodontal breakdown.

## ❖ COMBINATION CLASP IN STRESS RELIEVING:

- A combination clasp is one in which the retentive arm is made of a round flexible wrought wire and the reciprocal arm is of rigid metal.
- The round form of the clasp makes it equally flexible in all the directions.
- For this reason it is effective against the twisting stresses as well as the vertical dislodging forces.
- It also has the additional advantage of being easily adjustable.

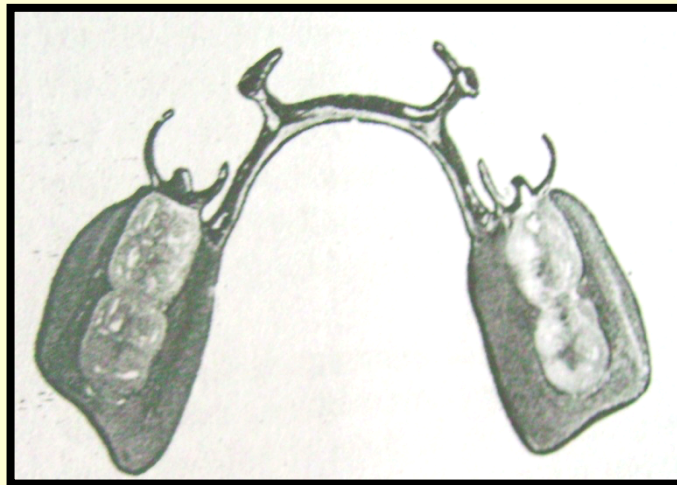

## ❖ PRECISION ATTACHMENTS:

- The precision attachment is the two-part mechanism whose female portion is housed within a casting on an abutment tooth.
- The counterpart or the male portion is matched to fit perfectly in to the female portion.

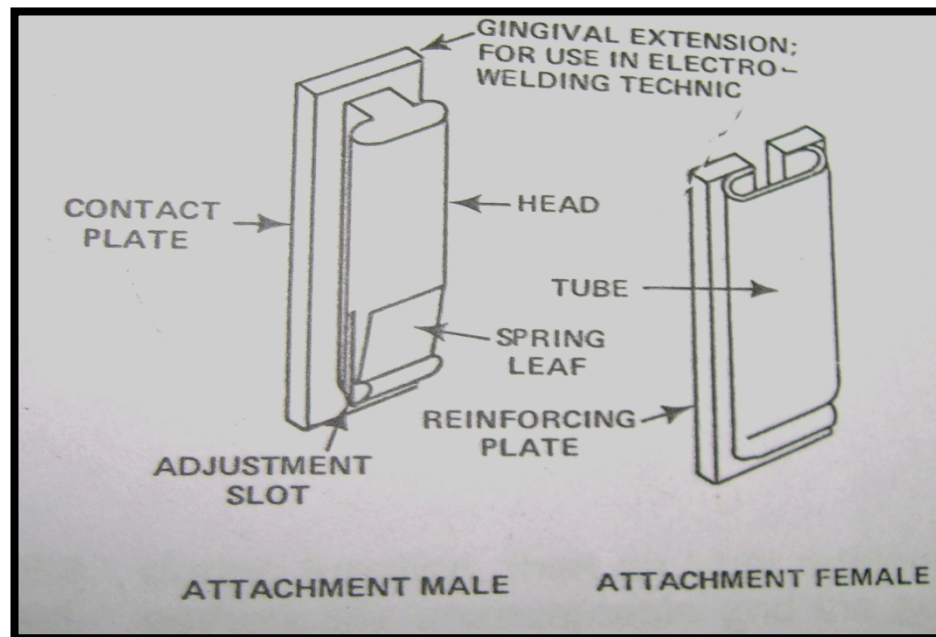

❖ **ADVANTAGES OF THE PRECISION ATTACHMENT:**

- the functional load is dispersed through the long axis of the tooth.
- Adequate retention is achieved without unnecessary force imparted to the abutment teeth.

❖ **DISADVANTAGES OF THE PRECISION ATTACHMENT:**

- Too much tooth reduction is required.
- Difficult to repair.
- They are much costly.
- Can not be used in cases with short clinical crowns.

❖ There are various types of precision attachments available. Some of which are shown as under:

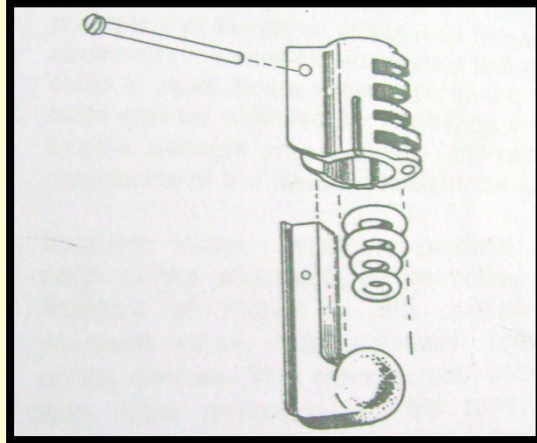

Dalbo attachment

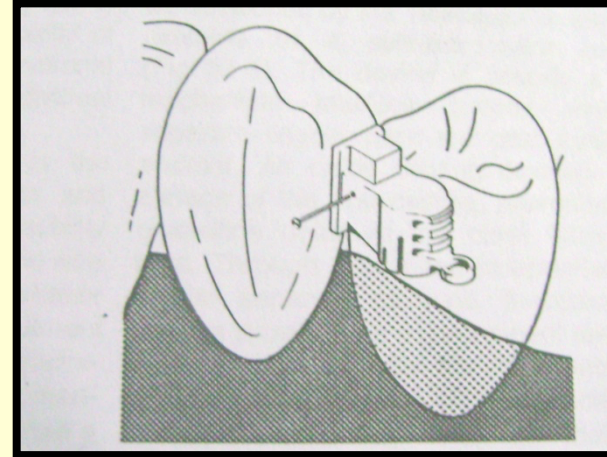

Stress breaker assembled in RPD

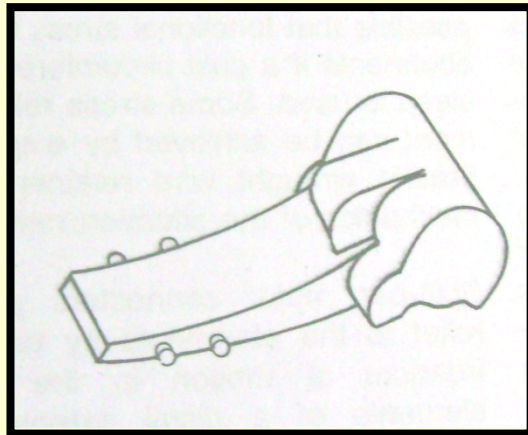

DE hinge attachment

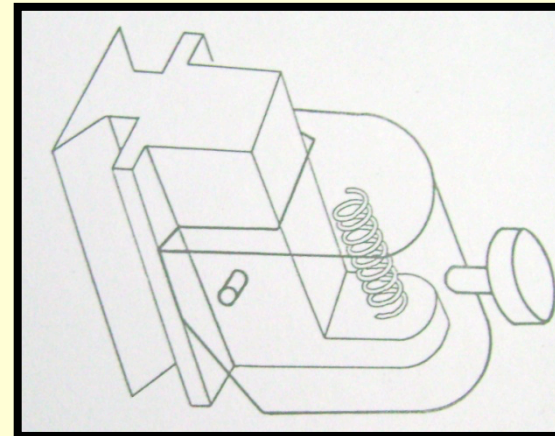

Chrismani attachment

THANK YOU